



**POWERTRUSION**  
**PRODUCTS**

## **PRODUCT BROCHURE**

Providing  
Leadership in Advanced Composite  
Cross Arm Technology



### **POWERTRUSION PRODUCTS CROSS ARM FEATURES**

- Forerunner in Polyurethane (PUR) Technology for Pultruded Cross Arms
- Non-Conductive/Advanced BIL
- Light Weight
- Field Drillable
- UV Protected
- Long Life Expectancy
- Environmentally Friendly
- Foam Filled - Denying Access to Water and Insects
- No Braces Required - Ease of Installation



Manufactured by  
**CREATIVE PULTRUSIONS, INC.**

# Powertrusion Products Cross Arm Ordering System

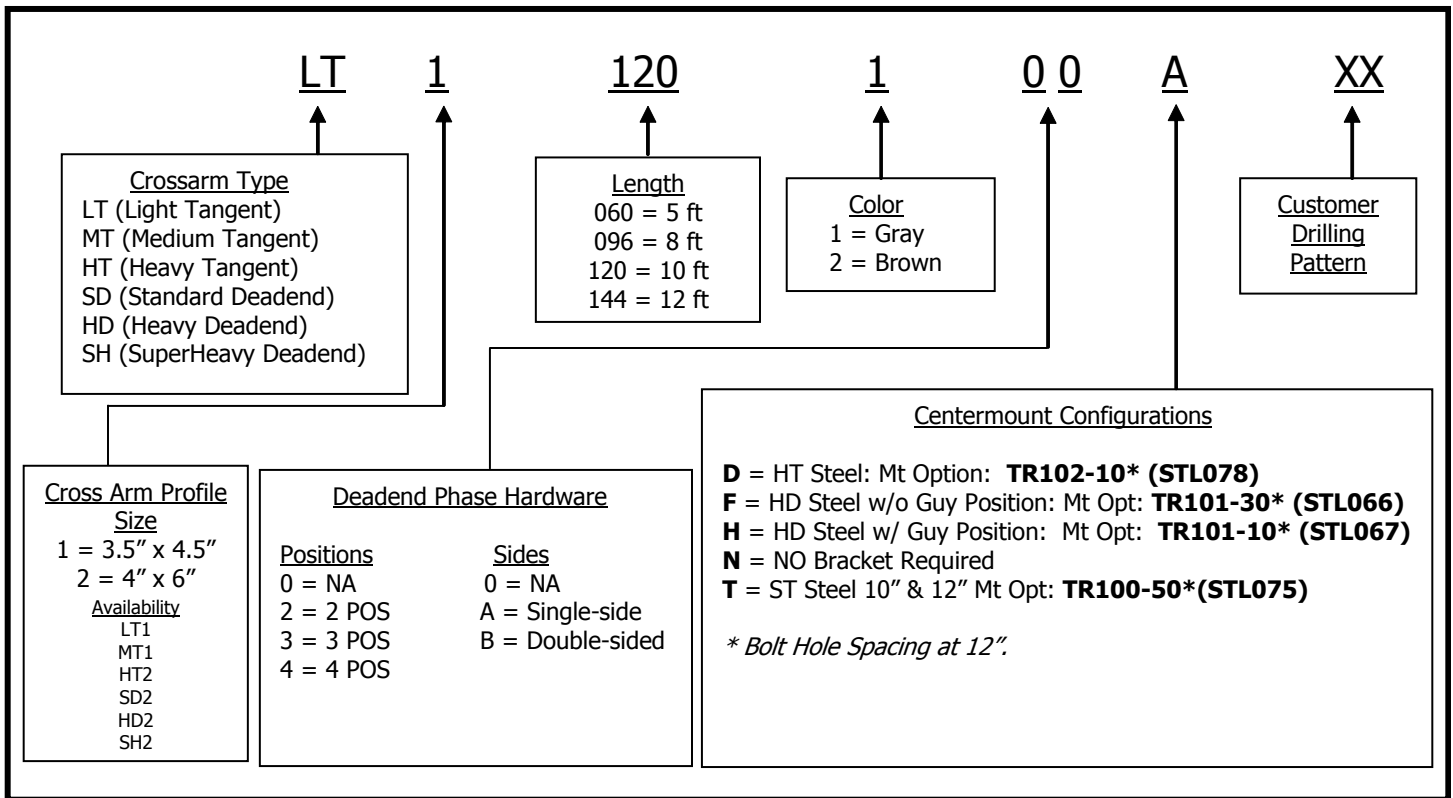

## Tangents

LIGHT TANGENT 3-1/2" X 4-1/2"			
Part Number	Length	Weight w/ Hardware**	Ultimate Load per Phase
LT1060100DXX	5' (60")	30 lbs.	5,000 lbs.
LT1096100DXX	8' (96")	39 lbs.	5,000 lbs.
LT1120100DXX	10' (120")	45 lbs.	3,800 lbs.

MEDIUM TANGENT 3-1/2" X 4-1/2"			
Part Number	Length	Weight w/ Hardware**	Ultimate Load per Phase
MT1060100DXX	5' (60")	30 lbs.	5,000 lbs.
MT1096100DXX	8' (96")	39 lbs.	5,000 lbs. *
MT1120100DXX	10' (120")	45 lbs.	3,800 lbs. *

SUPUR TUF POLYURETHANE HEAVY TANGENT 4" X 6"			
Part Number	Length	Weight w/ Hardware**	Ultimate Load per Phase
HT2096100DXX	8' (96")	53 lbs.	10,000 lbs.
HT2120100DXX	10' (120")	62 lbs.	9,000 lbs. *
HT2144100DXX	12' (144")	71 lbs.	8,000 lbs. *

\*Loads tested and achieved at EDM International Testing Facility

\*\*Weights include specified centermount and hardware.

Note: Tangents are RUS Accepted and Available with RUS Drilling Patterns. Please consult factory.

# Powertrusion Products Cross Arm Ordering System

## Deadends

<b>SUPURTUF POLYURETHANE STANDARD DEADEND</b>			
<b>4" X 6"</b>			
<u>Part Number</u>	<u>Length</u>	<u>Weight w/ Hardware**</u>	<u>Ultimate Load per Phase</u>
SD209612BFXX	8' (96")	67 lbs.	10,000 lbs.
SD212012BFXX	10' (120")	76 lbs.	9,000 lbs.
SD214412BFXX	12' (144")	85 lbs.	8,000 lbs.

<b>SUPURTUF POLYURETHANE HEAVY DEADEND</b>			
<b>4" X 6"</b>			
<u>Part Number</u>	<u>Length</u>	<u>Weight w/ Hardware**</u>	<u>Ultimate Load per Phase</u>
HD206012BFXX	5' (60")	54 lbs.	10,000 lbs.
HD209612BFXX	8' (96")	67 lbs.	10,000 lbs. *
HD212012BFXX	10' (120")	76 lbs.	9,000 lbs. *
HD214412BFXX	12' (144")	85 lbs.	8,000 lbs.

<b>SUPERHEAVY DEADEND</b>			
<b>4" X 6"</b>			
<u>Part Number</u>	<u>Length</u>	<u>Weight w/ Hardware**</u>	<u>Ultimate Load per Phase</u>
SH206012BFXX	5' (60")	66 lbs.	15,000 lbs.
SH209612BFXX	8' (96")	79 lbs.	15,000 lbs. *
SH212012BFXX	10' (120")	88 lbs.	12,500 lbs.
SH214412BXXX	12' (144")	97 lbs.	10,000 lbs.

\*Loads tested and achieved at EDM International Testing Facility

\*\*Weights include centermount, hardware, and two position double sided deadend hardware.

*Note: Deadends are RUS Accepted and Available with RUS Drilling Patterns. Please consult factory.*

### Centermount Weights

- D = 15 lbs.
- F = 25 lbs.
- H = 28 lbs
- T = 20 lbs.

### Centermounts

### POLE INSTALLATION

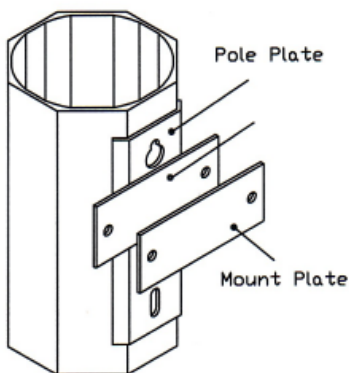

rev. 10.23.02

Typical Tangent Mount



Typical Deadend Mount



**Hardware Requirements:** Standard utility position hardware may be utilized in conjunction with the FRP arms. FRP cross arms exhibit high strength attributes. However, caution must be taken when applying torque to bolted connections. Bolt torque should be limited to 25 ft-lbs. Always use 3" x 3" x 1/4" square washers on the 4-1/2" x 3-1/2" tangent arms and 4 x 4" x 3/8" square washers on all dead end arm position hardware.

## **2 Position Single Sided**

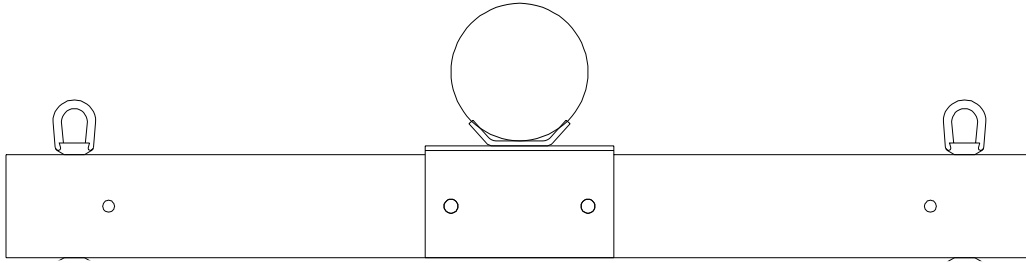

## **2 Position Double Sided**

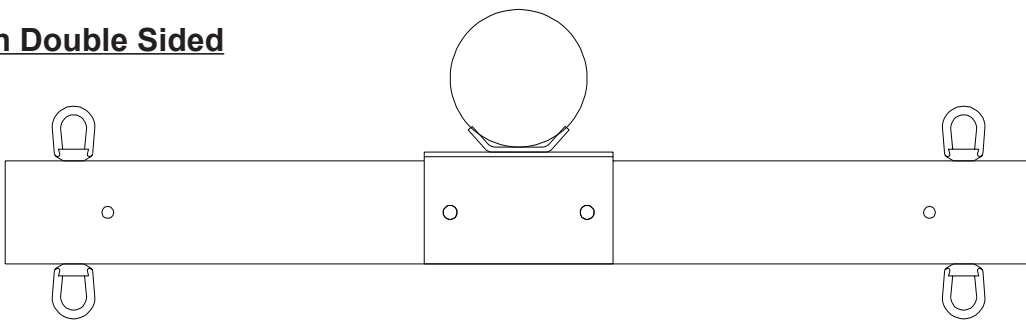

## **4 Position Double Sided**

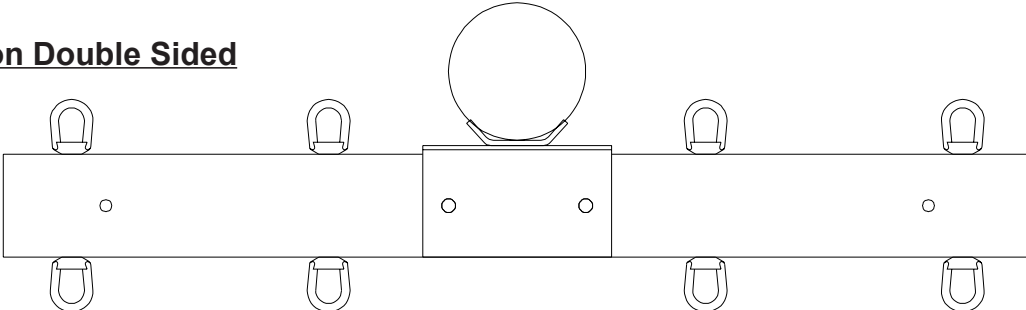

214 Industrial Lane ■ Alum Bank, PA 15521  
Phone: 888-274-7855 ■ Fax: 814-839-4276  
E-mail: [bguilliams@pultrude.com](mailto:bguilliams@pultrude.com)

[www.creativepultrusions.com](http://www.creativepultrusions.com)

[www.powertrusion.com](http://www.powertrusion.com)